

Linear Regulator Series

Linear Regulator Specifications

No.15020EAY18

A linear regulator data sheet includes a specifications table that lists output voltage values and precision. Besides, very important information such as maximum ratings, operating conditions and characteristic graphs are described in the table.

The absolute maximum rating is defined as a value that must not be exceeded even for a moment. Although some items are defined by a time component, such as short-circuit time, it is basically prohibited to exceed the absolute maximum rating in every case. And, for obvious reasons, a tolerance like $\pm 10\%$ is never assigned to values. We sometimes receive questions like: What will happen if a value exceeds the absolute maximum rating? How much margin does the system have? (These questions may be just a matter of interest.) However, they miss the point when it comes to considering the purpose of absolute maximum rating. You should make efforts so that the operating maximum value will not exceed the maximum rating or try to use a linear regulator model having the maximum rating that allows the operating maximum value.

It is important to identify the conditions that guarantee the specification values, for example, applied voltage and temperature. Actual use conditions do not always accord with specification-stipulated conditions. As a typical example, if a condition of $T_a=25^\circ\text{C}$ is given, its guaranteed value persistently is a value at $T_a=25^\circ\text{C}$. However, in actual use, a constant condition at $T_a=25^\circ\text{C}$ would be possible only

in a thermostatic bath. Therefore, in examining the specification value, it is necessary to verify whether the value applies to a single specific condition or a range of conditions, for example, a range of operating temperatures, and to confirm the value in a condition close to the actual use condition and operating condition of the designed equipment. To do this, a supplemental reference graph is often useful.

Lastly, the specification values include descriptions of any one or all of the minimum values (Min), maximum values (Max) and typical values (Typ). Among these, only the minimum value and maximum value are guaranteed. The typical value (Typ) is "an approximate value" based on characteristic distributions and statistical techniques. Basically, every product is designed based on the specification values. Then, which value should we use to design products? Although general designs might be based on typical values in principle, the design should be based on the values that pose the worst conditions. This selection depends on the know-how and experience of designers themselves.

This paper explains typical items in linear regulator specifications. However, other specification items may not be ignored. Reading a data sheet carefully is very important for designers, not only for linear regulators but also for other equipment.

Table of Contents

1. Input Power Supply Voltage Range3
 2. Output Voltage Range.....3
 3. Output Voltage Precision.....4
 4. Output Current4
 5. Input/Output Voltage Difference4
 6. Transient Response Characteristics.....5
 7. Ripple Rejection Ratio.....6
 8. Circuit Current.....7
 9. EN Pin (CTL/STBY Pin)8
 10. Line regulation9
 11. Load Regulation9
 12. Output Discharge9
 13. Soft Start10
 14. Input Capacitor.....10
 15. Output Capacitor.....10
 16. Power Dissipation11
 17. Overcurrent Protection11
 18. Thermal Shut Down12

1. Input Power Supply Voltage Range

The input power supply voltage range identifies two values. The range indicated in the absolute maximum rating shows the applicable extent of “input,” or the limitation of voltage application. This does not mean that the linear regulator operates normally within the given range. We check that the value is within this range, assuming an irregular voltage value.

Apart from the absolute maximum rating, the items entitled “recommended input range” and “operating input range” are given. Thus, you may refer to these items.

Figure 1 shows the relationship between the input range, output range and voltage difference between input and output (hereinafter referred to as “input/output voltage difference”). The effective input range is defined to be from the “output voltage + input/output voltage difference” to the “maximum input voltage.” Since the linear regulator allows “buck” operation only, it cannot operate even by inputting voltage below the “output voltage + input/output voltage difference.” Although what will happen if voltage lower than this limit is input varies depending on the IC circuit configuration, it is assumed in many cases that voltage as high as the “input voltage – input/output voltage difference” appears. However, its stability is not guaranteed. As input further lowers, the voltage level suddenly drops to 0V or so at a certain point, in general. Thus, it is important to set the Input/output condition based on a thorough understanding of the relationship given in Figure 1.

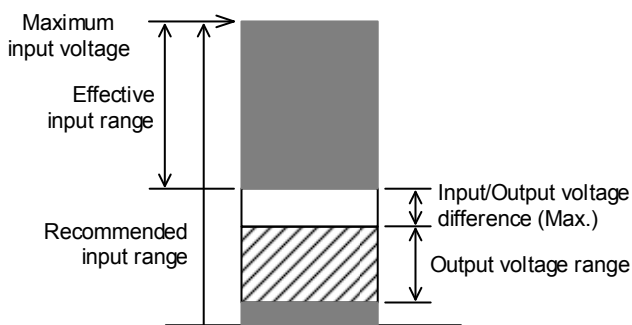

Figure 1 Relationship between Input Voltage and Output Voltage

2. Output Voltage Range

Since the output voltage range is a specification for variable output types of linear regulators, it does not correspond to the fixed output types such as those having a 5V-fixed output.

The output voltage range is defined as a voltage range settable as output voltage for variable output type linear regulators.

Basically, the minimum voltage settable by variable types becomes the output reference voltage of the output voltage range. Some ICs set the minimum output voltage higher than the output reference voltage, by using the operation limiting function of a protective circuit or other circuit block. The output reference voltage refers to the reference voltage (V_{REF}) for comparison purposes, which is connected to the error amplifier input. You can see that it is impossible to stabilize voltage lower than the reference voltage (V_{REF}) used in comparisons (Figure 2).

Since the reference voltage is a part of IC elements, it cannot be changed externally. Generally, CMOS series linear regulators use a reference voltage of approx. 0.8V and bipolar series linear regulators use one of approx. 1.2V. However, you should be careful not to select an IC that has a reference voltage of 1.2V for an application requiring 1V output, for example.

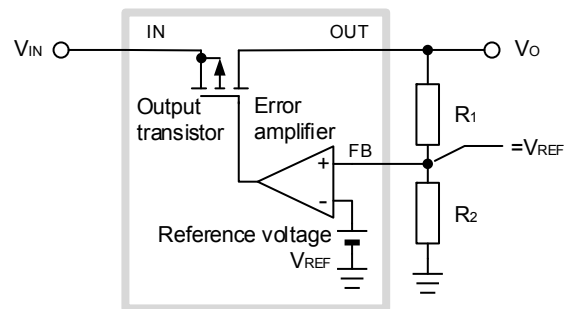

Figure 2 Outline of Internal Circuit

Going back to the subject of the output voltage range, the minimum voltage is the reference voltage and the maximum voltage is the “maximum input voltage – input/output voltage difference” (Figure 1).

Although the input/output conditions can be calculated from the above relationship, they may be limited by power loss. In some cases, it is required to calculate heat so as not to exceed the absolute maximum rating of the junction temperature and to make a trade-off depending on the conditions of input voltage, output voltage, output current and ambient temperature.

3. Output Voltage Precision

Output voltage precision is the output voltage tolerance of the fixed output types of linear regulators. While $\pm 5\%$ used to be the standard tolerance, high precision types of $\pm 1\%$ are widely available as of recent. Output voltage precision has a close relationship with temperature and output current.

Output voltage precision for variable output types of linear regulators corresponds to the precision of the reference voltage V_{REF} . This becomes the precision of the IC itself. Output voltage of variable output types is set by external resistors. Therefore, output precision of variable output types is calculated by adding the "tolerance of the resistors set as the output" to the "precision of the reference voltage".

The value of the resistors set as output conforms to the setting range in the data sheet, if any. For the bipolar type linear regulators, the error amplifier income current exists in the feedback pin. If the resistance value is too large, the current causes a voltage drop, which will cause an error in output voltage. On the contrary, if the resistance value is too small, the voltage error is reduced but the current capacity is also reduced, which will disable the normal feedback trigger for IC startup.

4. Output Current

The output current specifications stipulate the allowable output current range. Some data sheets stipulate the maximum value only. The maximum value means that output is allowed up to this value. Actually, current over this value flows. You must be careful with the maximum value because it has happened that the load was damaged due to a misunderstanding of the current limit to be applied at the indicated value. To check the limit value, you should refer to the overcurrent protection detection current or a characteristic graph by item. When this current is known, it will help determine measures for worst case conditions.

Then, is it possible to use the guaranteed output current all the time? Output current is limited by the junction temperature absolute maximum rating, keeping in mind the input/output conditions and ambient temperature conditions. For a linear regulator, heat calculation is one of the important items that is always required.

5. Input/Output Voltage Difference

The input/output voltage difference is the difference between the input voltage and output voltage required for the linear regulator to stabilize operation, which is also called the

"dropout voltage." As input voltage gets close to the output voltage, the linear regulator cannot maintain stable operations and accordingly output starts dropping in proportion to the input. Voltage at the beginning of this state, that is, the difference between the input voltage and output voltage required for stable operation, is called the "input/output voltage difference" (Figure 3). As a measurement condition, $V_{IN}=V_O \times 0.95$ may be described. This shows that the input voltage is set lower than the output voltage. You may be wondering if the IC correctly operates in this state. However, since the voltage is measured by simply focusing on the output transistor input/output voltage difference, it means that measurement starts at a point when the output starts dropping in proportion to the input as shown in Figure 3. Obviously, the output voltage is not stable at this time.

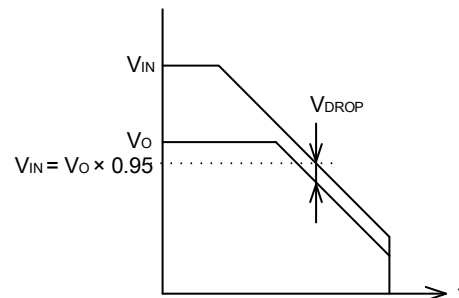

Figure 3 Input/Output Voltage Difference

Figure 1 given above shows the relationship between the input/output voltage and the input/output voltage difference. The input/output voltage difference differs depending on the IC circuit configuration. Compared to the standard type, an LDO features a rather small input/output voltage difference. Simply concerning the relationship, since the input/output voltage difference is smaller, an IC can operate at input voltages closer to the output voltage. This will be an important specification for battery-driven applications in which input voltage fluctuates. On the contrary, for applications that generate 5V from 12V, the input/output voltage difference is not important.

The graphs in Figs. 4 and 5 show the relationship between the input/output voltage difference, output current and temperature. As you can see, this can be defined as a parameter that fluctuates in its own way in relation to the temperature and output current. If designing an IC with the minimum margin in accordance with specifications at normal temperature, the IC may get hung up at high temperature. The characteristic graphs supply very important information about dropout voltage, etc. Figure 6 shows the measurement circuit of the input/output voltage difference.

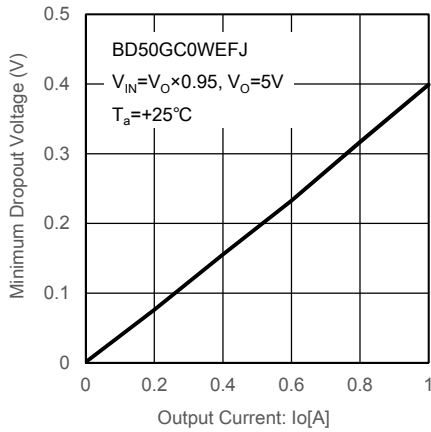

Figure 4 Input/Output Voltage Difference – Output Current

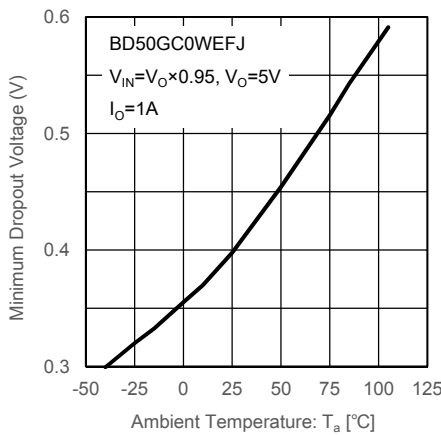

Figure 5 Input/Output Voltage Difference – Ambient Temperature

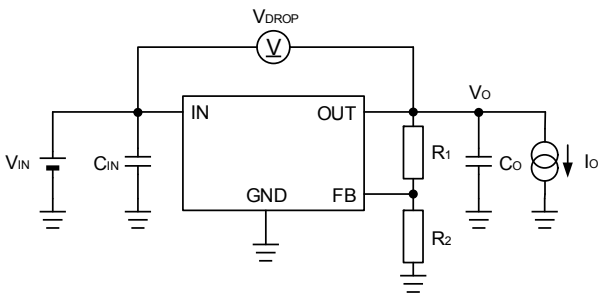

Figure 6 Input/Output Voltage Difference Measurement Circuit

6. Transient Response Characteristics

When output voltage fluctuates in response to a fluctuation in overcurrent, the linear regulator tries to return output voltage to the preset voltage value as shown in Figure 7. The time from the fluctuation in output voltage to the return to its original value is called the "transient response characteristic." Strictly speaking, this is the load transient response characteristic. The fluctuation (shift) in output voltage in

response to the increase/decrease in load in the steady state is presented with load regulation, which is a different concept from transient response.

Although the regulator operates stably, not only regulators but also any other devices require some time to respond to a change of state. When the output load fluctuation is very quick, the response from the linear regulator feedback (stabilization) loop cannot keep up. If the load current rapidly increases, the output voltage drops, and if the load current rapidly decreases, the output voltage increases (Figure 8). A general linear regulator has the circuit configuration shown in Figure 2. If the load current rapidly increases, the error amplifier error voltage drives the output transistor to supply current from the input to the output. Therefore, the output voltage drop can be rapidly recovered. On the contrary, when the load current rapidly decreases, the error amplifier error voltage merely turns OFF the output transistor. The boosted output voltage reduces slowly if the overload current is small because its discharge path lets only the load current flow. An ultra-low saturation (ultra-LDO) linear regulator developed for DDR memories and CPUs integrates an output transistor toward the sink, which allows the bi-directional reception of high speed transient response.

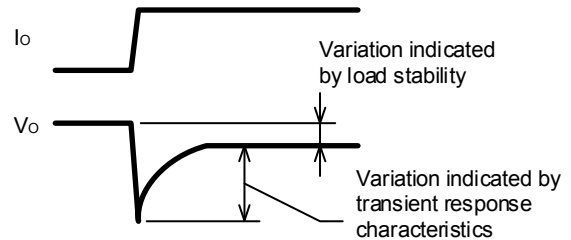

Figure 7 Transient Response Characteristics

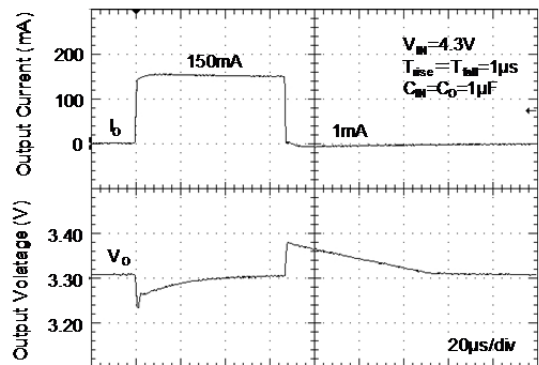

Figure 8 Actual Transient Response Waveform

Figure 9 shows a transient response characteristics measurement circuit. Two types of load resistors are provided to change the current value quickly via a transistor. When a load device is integrated, the load type is set to the CR mode to change the load by time-sharing and measure the response. The output current is monitored by a current probe, and the output voltage is measured by a voltage probe.

For applications subject to rapid changes in load current, transient response characteristics are critical factors. If the recovery of an output voltage that has been dramatically changed by load fluctuation is delayed, failures may arise; for example, the circuit may be reset or a data error may occur. To minimize such failures, it is necessary to select a linear regulator with excellent transient response characteristics. Although a switching regulator also has transient response characteristics, the characteristics of a linear regulator ensure relatively high speed thanks to its continuous loop control.

However, transient response characteristics are not guaranteed as a specification in most cases. This is because transient response characteristics are influenced by output capacity and wiring inductance, and, accordingly, it is impossible to determine defaults as a rule. You may refer to the characteristic values of a standard circuit example in a graph, if available. But, in the end, we still recommend measuring the transient response characteristics using real equipment because they vary also depending on the PCB layout as mentioned above.

7. Ripple Rejection Ratio

Ripple rejection ratio is a specification that stipulates how much ripple voltage in input can be removed in output. It is also called PSRR, input voltage ripple rejection rate, as well as other things, but regardless of what it is called, its

significance is the same. Ripple rejection ratio is often presented in units of dB. For example, 60dB means that input ripple is reduced to 1/1000, and ripple of 100mV may be reduced to 0.1mV.

$$\text{Ripple Rejection Ratio} = 20 \times \log \frac{\text{Output Ripple Voltage}}{\text{Input Ripple Voltage}} \text{ [dB]}$$

Ripple rejection ratio becomes important when the input ripple is large. Recently, switching regulators have become popular to the point that even applications where noise is a problem are likely to use switching regulators from the viewpoint of efficiency. However, some applications that cannot compromise S/N ratio may use the ripple rejection function of linear regulators in order to remove switching noise (ripple) in the output from switching regulators. Although this is indeed one of the effective solutions, it is necessary to carefully examine the input ripple frequency and frequency characteristics of the ripple rejection ratio. Generally, ripple rejection performance deteriorates as the frequency gets higher. Therefore, in cases having a high ripple frequency, the expected efficiency may not be obtained.

Figure 10 shows ripple rejection characteristics of a common linear regulator, in which the removal ratio against frequency gets lower. For example, approx. 5dB is measured at 1MHz, which means a removal ratio as small as 1/1.8. On the contrary, the switching frequency of switching regulators is as high as several hundreds kHz to several MHz. For example, if a 1MHz switching regulator has ripple of 100mV, ripple of 56mV is left. Recently, linear regulators with improved frequency characteristics have been developed. The example in Figure 11 shows that the ripple rejection ratio is 35dB at 1MHz and that ripple can be reduced to 1/56, that is, 1.8mV.

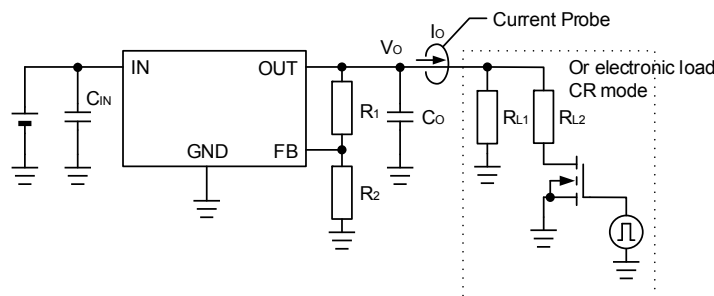

Figure 9 Transient Response Characteristics Measurement Circuit

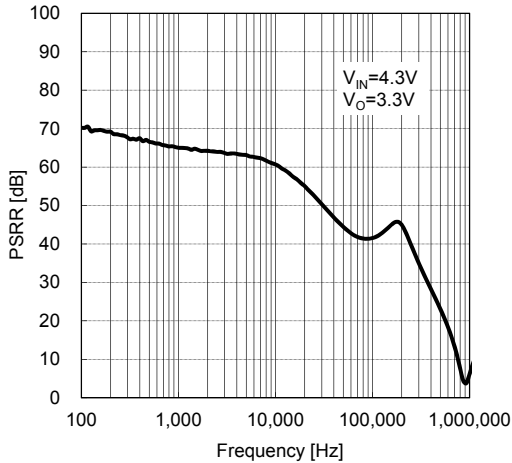

Figure 10 General Ripple Rejection Characteristics

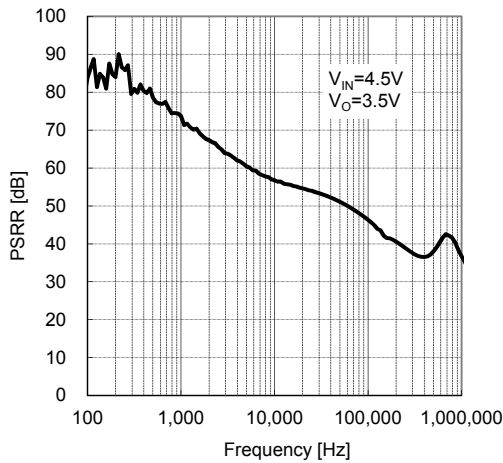

Figure 11 Ripple Rejection Characteristics with Preferable Frequency Characteristics

Figure 12 shows a ripple rejection ration measurement circuit. The ripple voltage is supplied to the IC input via a signal generator. As the power supply output impedance is low, and signals cannot be injected into the IC input line in the

current condition, resistance R_G of approx. 10Ω is inserted in the DC power supply output to increase impedance. Since this resistance generates a voltage drop, the DC power supply voltage needs to be adjusted to the regulated voltage at an IC input port. In order to protect input resistance from damage caused by applying DC current, the signal generator injects ripple signals (sine waves) through a capacitor coupling. In this way, use of a bipolar power supply instead of a circuit superimposing ripple signals on DC will simplify circuit configuration. The ratio of ripple voltage $V_{IN(AC)}$ injected by the signal generator to ripple voltage $V_{O(AC)}$ measured in output will be calculated as the ripple rejection ratio.

8. Circuit Current

Circuit current is the current consumed inside the IC. This may be described as consumption current or bias current. Output voltage variable types of linear regulators may contain current flowing in an external resistor to set the voltage. A smaller resistance value has more influence on the circuit current. An IC incorporates driver circuits to drive reference voltage sources, error amplifiers and output transistors, and protection circuits to cope with overcurrent and overheat. Among the circuit blocks, the driver circuit that drives the output transistor consumes the largest amount of current. When the output is of bipolar transistor type, the driver circuit needs to drive current at the output transistor base. Therefore, as the output current increases, the driver current (= circuit current) increases (Figure 13). On the contrary, when the output is of MOSFET type, the driver circuit drives the output transistor gate using voltage. Therefore, even if the output current increases, the circuit current hardly increases (Figure 14).

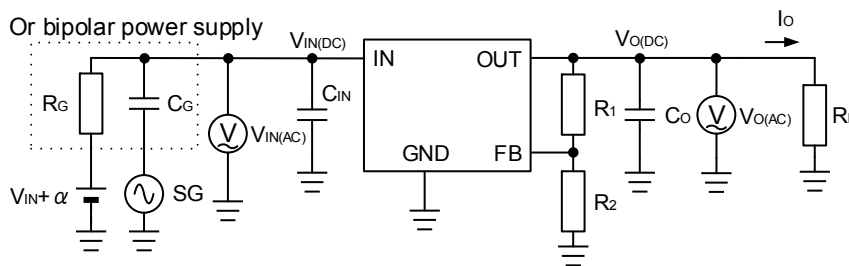

Figure 12 Ripple Rejection Ratio Measurement Circuit

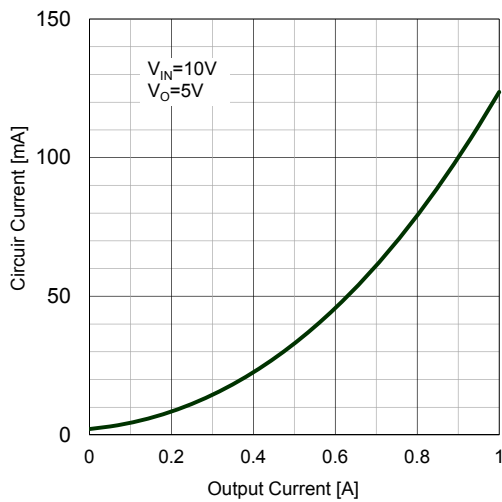

Figure 13 Bipolar Output Type Current Circuit

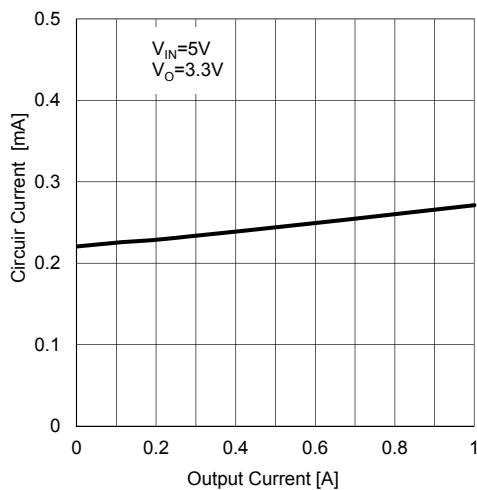

Figure 14 MOSFET Output Type Current Circuit

CMOS types and Bi-CDMOS types feature small currents of several hundreds of μA or less, while bipolar types feature rather large currents of several mA. Especially, since in-vehicle linear regulators reduce power consumption during standby and need to reduce power consumption of the car battery, the IC consumption current is reduced to several μA to several tens of μA .

Figure 15 shows a circuit current measurement circuit. Linear regulators often have power supply pins and input pins common in the IC circuit. Since the IC consumption current cannot be separately measured from the IC load current on the input pin, it is measured at the GND pin.

An IC having a shutdown function adds shutdown circuit current as a specification item. It may be indicated as standby circuit current. Literally, this is the circuit current when the IC is in the shutdown state, or in other words, the leak current for all elements. When the standby current is

important for power saving equipment such as a battery-driven product, it is recommended to select an IC whose Max value is small. When zero is set for the Typ value, it means that the value is not actually zero but extremely close to zero. As described in the beginning of this application note, Typ (typical value) is an "approximate value" analyzed by characteristic distributions and statistical techniques.

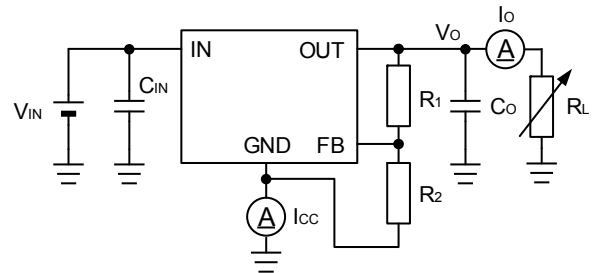

Figure 15 Circuit Current Measurement Circuit

9. EN Pin (CTL/STBY Pin)

An EN pin is inscribed on an IC having a shutdown function and is capable of selecting the IC mode between operation and shutdown in response to the pin voltage state. Besides EN (Enable) pin, other names such as "CTL pin," "standby control pin" or "output control pin" may be used.

Let's see an example in which the Low voltage and High voltage specifications are described as in Figure 16. The relationship of the voltage in this specification is given in Figure 17. This means that the EN Low voltage should be set between 0V and 0.8V; it does not mean that the Low voltage threshold is between 0V and 0.8V. Similarly, this means that the EN High voltage should be set between 2.4V and 14V. The threshold voltage value of the EN pin is somewhere between 0.8V and 2.4V, and the value is not guaranteed. That is, a range from 0.8V to 2.4V is logically an indefinite range and corresponds to a setting disable range.

Next, you will see the "pin bias current" or "pin input current." This denotes the current that flows to the pin when voltage is applied there, which mainly flows to the pull-down resistor inside the IC. Therefore, as the applied voltage increases, the input current increases. To control the pin through the resistor, the pin voltage may not rise to the High voltage due to a voltage drop caused by resistance. Due consideration should be taken of this possibility.

Some CMOS LDOs are configured with a pull-down current source instead of a pull-down resistor inside the IC. In this case, the input current becomes constant even when the voltage applied to the pin increases.

| Item | Code | Min | Typ | Max | Unit |
|-----------------|----------------|-----|-----|-----|------|
| EN Low voltage | $V_{EN(Low)}$ | 0 | - | 0.8 | V |
| EN High voltage | $V_{EN(High)}$ | 2.4 | - | 14 | V |

Figure 16 Example of EN Pin Specifications

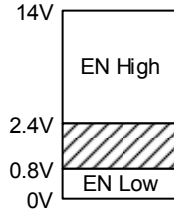

Figure 17 EN Pin Voltage Relationship Diagram

10. Line regulation

Line regulation is a specification that indicates the stability of the output voltage against the fluctuation of the input voltage; it is also called "line regulation." This presents how much the output voltage fluctuates when setting the input voltage to High, using the output voltage at a certain input voltage as a reference. Figure 18 shows the line regulation characteristics. As a reference input voltage, a value calculated by adding the maximum value of the minimum input voltage to the output voltage or a value calculated by adding 1V to the output voltage is often used. As the input voltage after fluctuation, the maximum input voltage of the IC is entered. This corresponds to the effective voltage range of Figure 1. Although the output voltage is monotonously increased in this example, the monotonous increase or decrease may not go in a single direction. Figure 19 shows a measurement circuit.

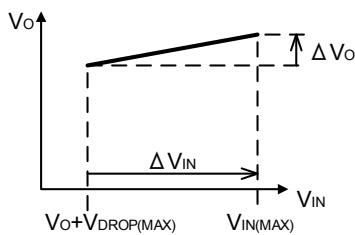

Figure 18 Line Regulation Characteristics

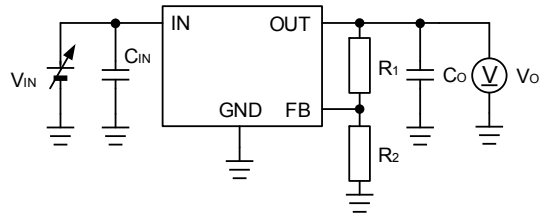

Figure 19 Line Regulation Measurement Circuit

11. Load Regulation

Load regulation is a specification that indicates the stability of the output voltage against the fluctuation in load current; it is also called "output stability" or "load regulation." This presents how much the output voltage fluctuates when the load current flows to the maximum in the stable state, using the output voltage at zero or a small load current as a reference (Figure 20). Load transition response characteristics, which present the fluctuation in output voltage in response to the increase/decrease in load in the transient state, will be separately considered in terms of load regulation (Figure 7). Figure 21 shows a measurement circuit.

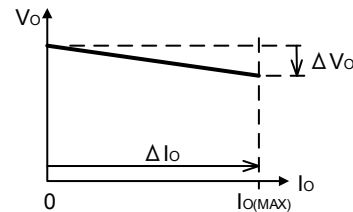

Figure 20 Load Regulation Characteristics

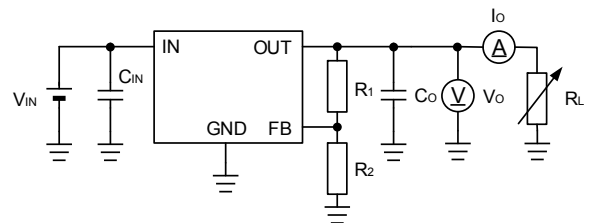

Figure 21 Load Regulation Measurement Circuit

12. Output Discharge

An output discharge circuit is capable of synchronizing with timing to turn OFF the regulator output and forcedly discharging the output capacitor charge through the EN (STBY) pin. This circuit is integrated in some linear regulators. When power management is frequently (quickly) performed such as in a portable device, it takes time for the output capacitor to discharge naturally. By reducing this time with forced discharge, you may program the ON/OFF sequence of each system block easily. The specifications describe discharge resistance values.

To activate this function, voltage must be always supplied to the IC VIN pin and the output must be controlled through the EN (STBY) pin. By controlling output ON/OFF using the voltage from the VIN pin, the voltage turns OFF on the VIN pin and the power supply to the output discharge circuit. Accordingly, this function is disabled, thus causing natural discharge.

Figure 22 shows the IC characteristics without output discharge. Figure 23 shows the IC characteristics with output discharge. In this example, the discharge speed is 8,000 times faster.

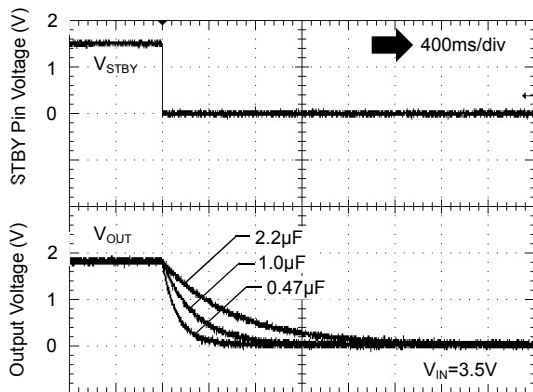

Figure 22 IC Characteristics without Output Discharge

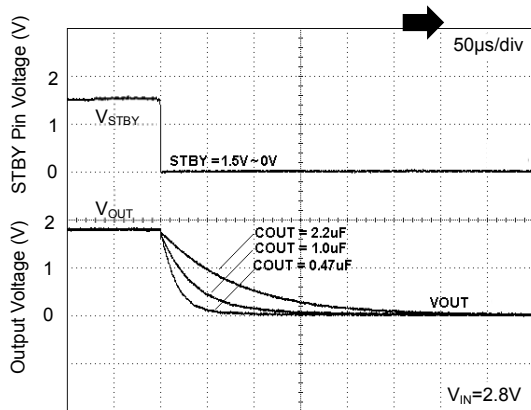

Figure 23 IC Characteristics with Output Discharge

13. Soft Start

Rush current flows to the output capacitor at power ON. A soft start is a function that reduces overshoot or rush current by slowly starting the output voltage; it is integrated in a part of linear regulator ICs. In the soft start waveform in Figure 24, a capacitor of 100µF is connected to the output. After power ON from the EN pin, output voltage rises from 0V to 3.3V in approx. 600µs. The output current is fixed to approx. 400mA, which proves that the rush current is reduced. capacity and withstand voltage for the sake of reducing costs

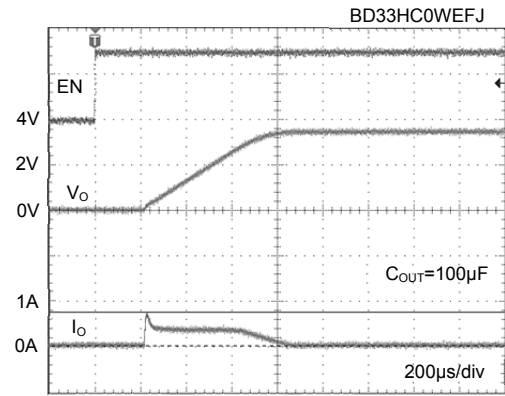

Figure 24 Soft Start Waveform

14. Input Capacitor

An input capacitor is a ceramic capacitor with good high frequency characteristics of 0.1µF to 1µF, connected between the IC input pin and ground. It is recommended to place the input capacitor within 5 mm of the IC input pin. The capacity value is determined in reference to the data sheet of each IC. A bulk capacitor with large capacity can be placed apart from the IC without difficulties. The capacity of bulk capacitor is determined appropriately so that the ripple voltage generated by the ripple current will be within the design value range.

15. Output Capacitor

An output capacitor is a very important component capable of compensating the phase of the IC internal amplifier and suppressing the output ripple voltage.

Recently, many low-ESR (equivalent series resistance) type capacitors have been manufactured, including large-capacity ceramic capacitors, low-impedance aluminum electrolytic capacitors and polymer capacitors. Thus, it is necessary to check over the data sheet of the IC whether a low-ESR capacitor can be used as an output capacitor. Old type linear regulators have been designed to enable a high-ESR output capacitor to compensate phase for the internal amplifier, since these capacitors were not common when they were developed. If using a low-ESR output capacitor with these ICs, a phase delay occurs followed by a high probability of abnormal oscillation. You may refer to standard values available on the data sheet. However, since the selection range of available capacitors is rather narrow, it is better to use an IC compatible with a low-ESR capacitor so as to reduce power and the risk imposed on design. As an example of risk, a case may be assumed where a person who does not know the component selection process changes the current capacitor to an appropriate capacitor having the same capacity and withstand voltage for the sake of reducing costs after mass-production, only to fail because of abnormal

oscillation.

If the minimum capacity value is described in the data sheet, that value is used as a standard. However, when the ripple current is large or large current flows transiently, the ripple voltage may not be within the design value range. In this case, the capacity value should be increased as appropriate, although power supply rise/fall become slow. When using the minimum capacity value, due consideration must be given to temperature characteristics, DC bias characteristics and deterioration of capacity due to tolerance. Otherwise, the IC may possibly oscillate. It is necessary to select a capacitor based on a good understanding of the characteristics of each capacitor; for example, an electrolytic capacitor is subject to severer capacity deterioration at low temperature and a ceramic capacitor is subject to capacity deterioration due to DC bias.

16. Power Dissipation

As a linear regulator is subject to large power loss under certain conditions, the package power dissipation is an important item to judge the applicable range. However, it is necessary to calculate the power loss from the input/output voltage difference and output current, and make sure that the chip temperature will not exceed the absolute maximum rating of the junction temperature, using the package surface temperature, in reference to the package thermal characteristic parameter (thermal resistance).

The specifications may describe various numeric values for the type of package. This is because the power dissipation varies by the substrate type (difference in the number of layers and copper foil area) in the case of surface mounted packages that radiate heat to the substrate. The chip temperature is estimated using the power dissipation data close to that of the substrate to be actually used.

17. Overcurrent Protection

An overcurrent protection circuit is provided in order to prevent damage to the IC caused by overcurrent generated when the IC output is short-circuited to ground. This protection function serves to protect the linear regulator IC from damage. To protect the set itself, you should consider integrating a fuse or other current limiting device.

The overcurrent protection characteristics are as shown in Figure 25. According to the figure, this is called the "fold-back characteristic." Point A presents the overcurrent protection detection current given in the specifications. When detecting overcurrent, the fold-back current circuit is

activated to reduce the output voltage. The operation reaches Point B after further throttling the current repeatedly along with the drop in output voltage. Point B is the output short-circuit current given in the specifications. Since the power loss and heat generation become small at point B, this can be defined as a safety protection circuit for protecting the IC from damage. However, the above-mentioned state continues until the cause of the overcurrent is removed. After the overcurrent state is eliminated, the output voltage automatically recovers. The fold-back current circuit may disable IC starting when the load is on a stable current source or when the output is a negative voltage at startup. To avoid this, overcurrent protection characteristics with the overcurrent limit circuit shown in Figure 26 are prepared; the circuit is said to be a "dropping type."

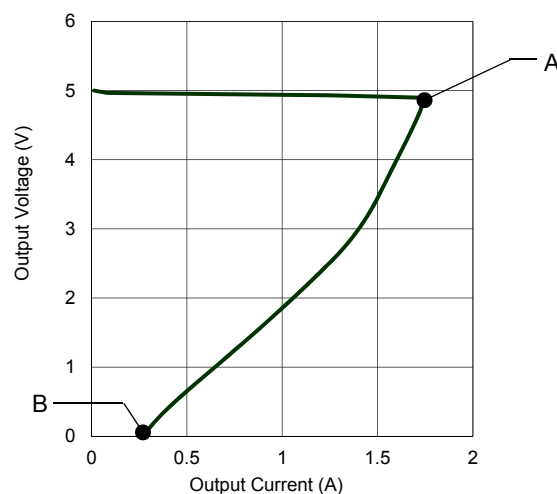

Figure 25 Overcurrent Protection Characteristics with Current Fold-Back Circuit

When an overcurrent state is detected, the overcurrent limit circuit is activated, the output current becomes stable and the voltage drops vertically. In the above example, the current limit value is switched in two steps in response to the output voltage. Although the dropping type circuit offers excellent current control, it must be used together with the overheat protection circuit because its output current, unlike that of the current fold-back circuit, does not lower in response to the drop in output voltage and it is prone to overheating when output is short-circuited to ground. A method combining the safety of the current fold-back circuit and the excellent control of the overcurrent limit circuit is also available.

The methods described above enable the output voltage to automatically recover after the overcurrent state is eliminated. However, some circuit types turn OFF the latching output when the overcurrent state continues. In this case, the

output stays OFF after the overcurrent state is eliminated and does not recover until the IC power is turned ON again. Thus, it is necessary to check whether your IC is of auto-recovery type or latch type on the data sheet.

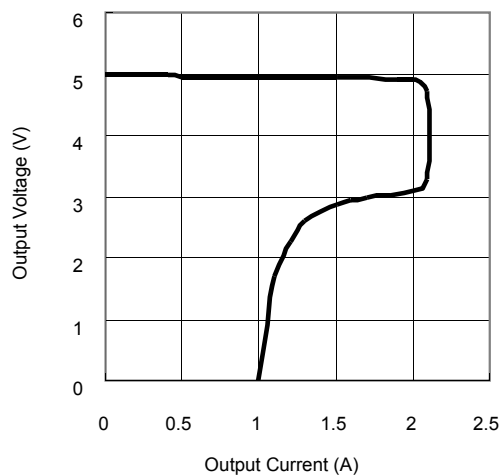

Figure 26 Overcurrent Protection Characteristics with Overcurrent Limit Circuit

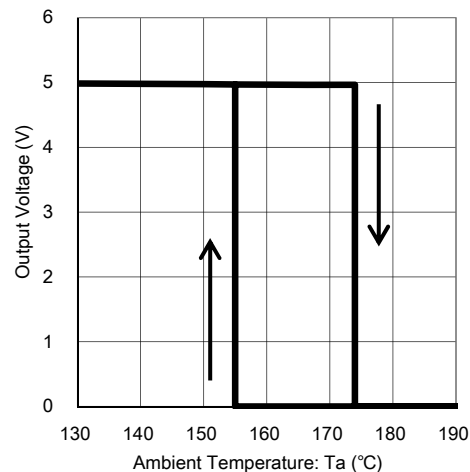

Figure 27 Thermal Shut Down Characteristics

18. Thermal Shut Down

In order to prevent damage to the IC due to overheating of the IC chip in excess of the junction temperature because of output short-circuiting or increase in power loss, most linear regulators integrate a thermal shut down circuit, which is also called "temperature protector" or "thermal shutdown." Note that this protection function is provided to protect the linear regulator IC from damage caused by overheating; it is not intended to replace the essential thermal shut down function of the set itself.

The thermal shut down circuit turns OFF the linear regulator output whenever the IC chip temperature exceeds the maximum junction temperature so as to reduce the chip temperature by shutting down the output current. Once the chip temperature lowers, the thermal shut down circuit turns ON output again to start supplying output current. Output ON/OFF operation is repeated until the cause behind the higher chip temperature is removed. Even if the output ON/OFF operation repeatedly continues, the IC will not be damaged in the short-run. However, an increase in failure rate may be possible.

Some latching types of IC turn OFF the output in an overheat state. In this case, the output stays OFF after the chip temperature lowers and the output does not recover until the IC power is turned ON again. Thus, it is necessary to check whether your IC is of auto-recovery type or latch type on the data sheet.

Notes

- 1) The information contained herein is subject to change without notice.
- 2) Before you use our Products, please contact our sales representative and verify the latest specifications :
- 3) Although ROHM is continuously working to improve product reliability and quality, semiconductors can break down and malfunction due to various factors.
Therefore, in order to prevent personal injury or fire arising from failure, please take safety measures such as complying with the derating characteristics, implementing redundant and fire prevention designs, and utilizing backups and fail-safe procedures. ROHM shall have no responsibility for any damages arising out of the use of our Products beyond the rating specified by ROHM.
- 4) Examples of application circuits, circuit constants and any other information contained herein are provided only to illustrate the standard usage and operations of the Products. The peripheral conditions must be taken into account when designing circuits for mass production.
- 5) The technical information specified herein is intended only to show the typical functions of and examples of application circuits for the Products. ROHM does not grant you, explicitly or implicitly, any license to use or exercise intellectual property or other rights held by ROHM or any other parties. ROHM shall have no responsibility whatsoever for any dispute arising out of the use of such technical information.
- 6) The Products are intended for use in general electronic equipment (i.e. AV/OA devices, communication, consumer systems, gaming/entertainment sets) as well as the applications indicated in this document.
- 7) The Products specified in this document are not designed to be radiation tolerant.
- 8) For use of our Products in applications requiring a high degree of reliability (as exemplified below), please contact and consult with a ROHM representative : transportation equipment (i.e. cars, ships, trains), primary communication equipment, traffic lights, fire/crime prevention, safety equipment, medical systems, servers, solar cells, and power transmission systems.
- 9) Do not use our Products in applications requiring extremely high reliability, such as aerospace equipment, nuclear power control systems, and submarine repeaters.
- 10) ROHM shall have no responsibility for any damages or injury arising from non-compliance with the recommended usage conditions and specifications contained herein.
- 11) ROHM has used reasonable care to ensure the accuracy of the information contained in this document. However, ROHM does not warrant that such information is error-free, and ROHM shall have no responsibility for any damages arising from any inaccuracy or misprint of such information.
- 12) Please use the Products in accordance with any applicable environmental laws and regulations, such as the RoHS Directive. For more details, including RoHS compatibility, please contact a ROHM sales office. ROHM shall have no responsibility for any damages or losses resulting from non-compliance with any applicable laws or regulations.
- 13) When providing our Products and technologies contained in this document to other countries, you must abide by the procedures and provisions stipulated in all applicable export laws and regulations, including without limitation the US Export Administration Regulations and the Foreign Exchange and Foreign Trade Act.
- 14) This document, in part or in whole, may not be reprinted or reproduced without prior consent of ROHM.



Thank you for your accessing to ROHM product informations.
More detail product informations and catalogs are available, please contact us.

ROHM Customer Support System

<http://www.rohm.com/contact/>